

PROJECT:	TYPE:
LOCATION:	CAT:



Description

The robust Pro 30 extrusion is great for indoor use when an angled application is necessary.

Features

- Includes (1) double anodized aluminum corner mounting plate piece and (1) non-anodized aluminum faceplate insert
- Use tape light, clips, right and left ends, and lens to create a complete fixture (tape light and accessories sold separately)

Mounting

Surface mount via screws. Holes should be drilled where marked by the embossed lines on the corner mounting plate; only one edge needs to be drilled. If you mount using the longer edge, you need to use screws and holes so the heads of the screws do not collide with the faceplate insert. For example, screws should have countersunk heads with a diameter of no more than 5mm and the holes should not exceed 3mm in diameter.

Applications

Angled areas, undercabinets, bar areas, window and retail displays

Profile Dimensions

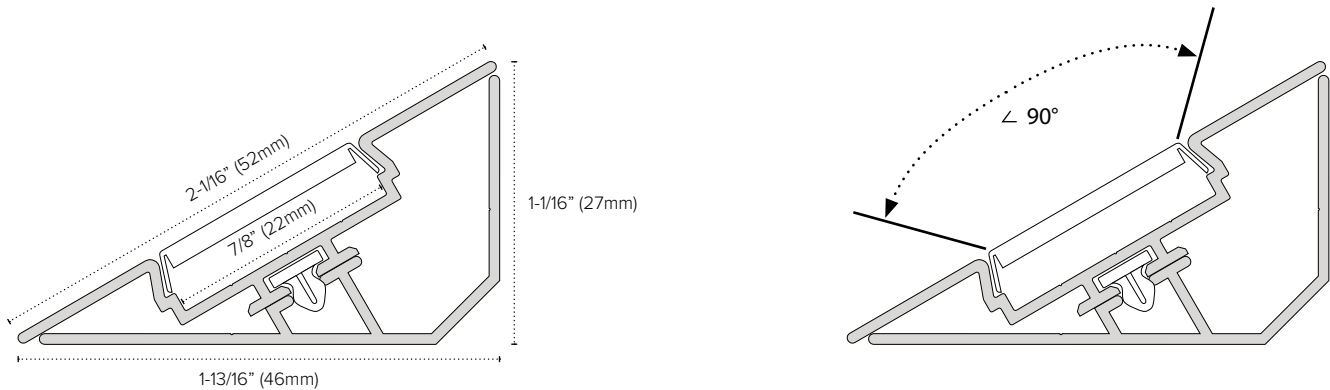

Ordering Information

Part Number	Description
PE-PRO30-1M	Pro 30 corner Extrusion with Faceplate Insert
PE-PRO30LENS-1M	frosted polycarbonate UV lens
PE-PRO30-RIGHT	Polypropylene plastic end cap for RIGHT end
PE-PRO30-LEFT	Polypropylene plastic end cap for LEFT end
PE-SLOT-CLIP	Pro 30 plastic slot clips (Required for installation; suggested 4 per meter)

*Pro30 extrusion is available as special order only.
For special orders, please contact us at: Quotes@PrizmLighting.com